

**Facts about Fibertex**

The Fibertex Group is a market leading manufacturer of needlepunch and spunmelt nonwovens owned by the industry conglomerate Schouw & Co. Headquartered in Aalborg, Denmark, with production facilities in Denmark, Malaysia and in the Czech Republic, Fibertex is globally represented.

Since its foundation in 1968, Fibertex continuously expanded and today manufactures nonwovens for customers all over the world for many different applications. Our main application areas are Personal Care, Furniture and Bedding, Flooring, Automotive, Filtration, Construction, Horticulture and Do-it-Yourself.

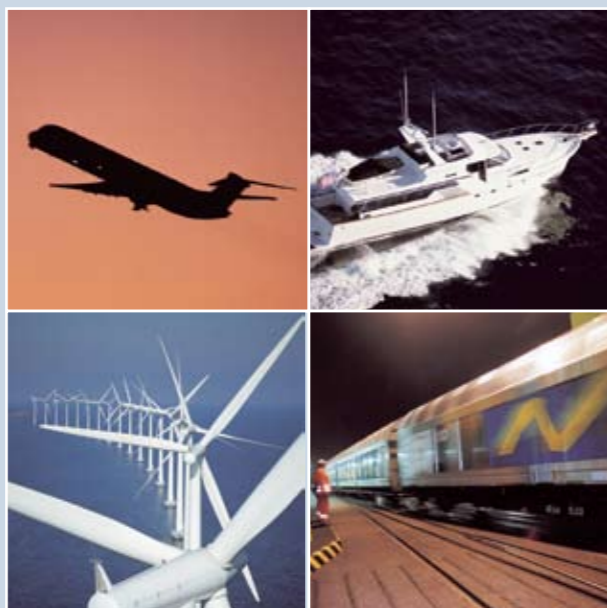

Superior peeling properties

Less resin dust

Process optimisation

Cost saving



Making the perfect match

Distributor:

**Compoflex®**

Composites made easy

[compoflex.fibertex.com](http://compoflex.fibertex.com)

**Fibertex A/S**  
 Box 8029  
 Svendborgvej 2  
 DK-9220 Aalborg Ø  
 Denmark

Tel. +45 96 35 35 35  
 Fax +45 98 15 85 55  
 E-mail [fibertex@fibertex.com](mailto:fibertex@fibertex.com)  
 Web [www.fibertex.com](http://www.fibertex.com)  
 Web [compoflex.fibertex.com](http://compoflex.fibertex.com)



# Compoflex®

Replace **3** products with **1** – Save **time** and **money**

## What is Compoflex®?

The Compoflex® products are breathable microporous peeling materials. Designed to replace consumables in composite manufacturing, Compoflex® offers direct benefits in your process:

### • Superior peeling properties

The microporous surface and the low surface tension of PP nonwovens ensure that Compoflex® peels at 1/5 of the force needed to peel conventional peelply.

### • Time and cost-savings

Depending on the process Compoflex® replaces several consumables. Fewer consumables combined with easy peeling reduce costs and handling time simplifying the process considerably.

### • Easy peeling minimising resin dust

Compoflex® peels easily and hardened resin remains in the liner reducing the amount of airborne resin dust. The peeling force required when not using Compoflex® generates intensive resin dust activity causing an unhealthy working environment.

## COMPOFLEX® 150 For resin infusion

In the resin infusion process the dry fibre material is placed directly in the mould. A distribution fabric is installed to ensure correct resin flow and optimal vacuum distribution. Between the dry fibre material and the distribution fabric a peel ply is installed as a separator. Compoflex® 150 substitutes the peel ply and ensures easy peeling leaving a clean, bondable surface.

Designed without a bleeder layer Compoflex® 150 is ideal for the resin infusion process.

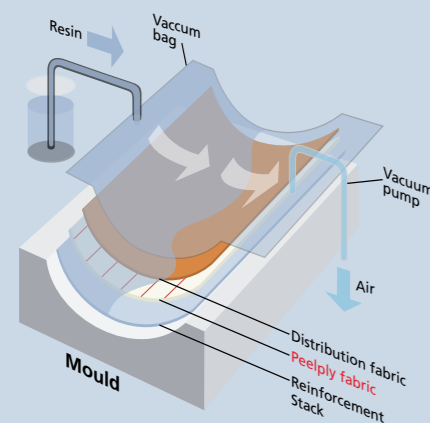

Standard resin infusion

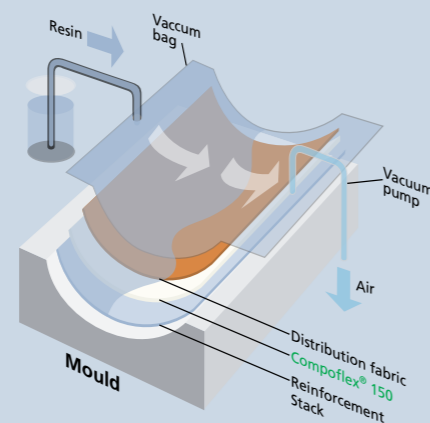

Resin infusion using Compoflex®

Compoflex® 150 properties		
Thickness at 2 kPa	mm	0.6
Resin Capacity	cm <sup>3</sup> /m <sup>2</sup>	305
Tear Strength (MD)	N	185
Tear Strength	N	120
Pore Size	µm	<10
Composition		100% Polypropylene
Process		Infusion

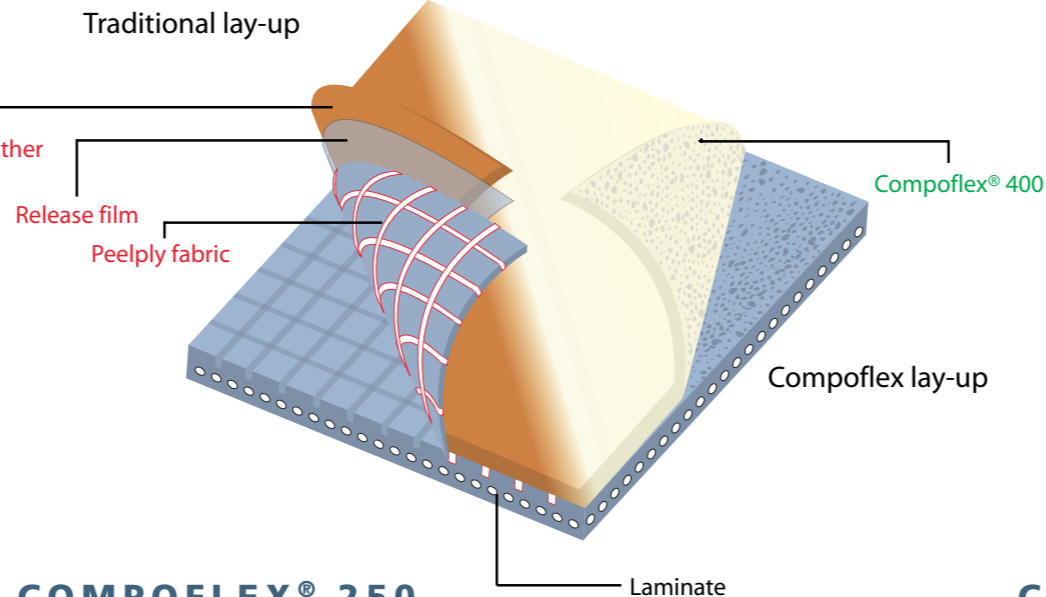

## COMPOFLEX® 250 For filament winding

In the filament winding process fibres are impregnated with resin and wound directly onto a rotating steel form. Several layers of peelply are wound over the fibres to absorb surplus resin. Using Compoflex 250 instead of peelply will increase the resin absorption per layer and often one layer of Compoflex 250 will be sufficient.

Designed with a medium size bleeder layer Compoflex® 250 is ideal for the filament winding process.

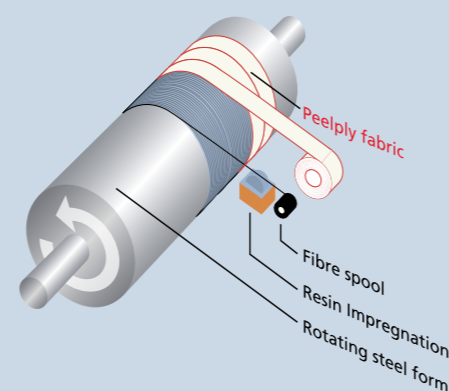

Standard filament winding

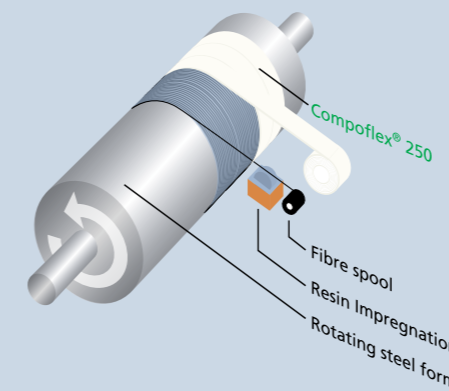

Filament winding using Compoflex®

Compoflex® 250 properties		
Thickness at 2 kPa	mm	1.3
Resin Capacity	cm <sup>3</sup> /m <sup>2</sup>	810
Tear Strength (MD)	N	350
Tear Strength	N	230
Pore Size	µm	<10
Composition		100% Polypropylene
Process		Filament winding and Vacuum bagging of pre-pregs

## COMPOFLEX® 400 For vacuum bagging

In the vacuum bagging process the lay-up consists of a laminate, peel ply (optional), release film and a breather/bleeder. Compoflex® 400 substitutes the peelply, release film and breather/bleeder simplifying the process considerably.

Designed with a maximum size bleeder layer Compoflex® 400 is ideal for vacuum bagging.

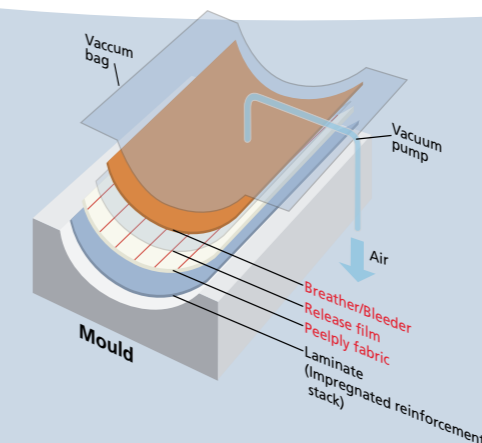

Standard vacuum bagging

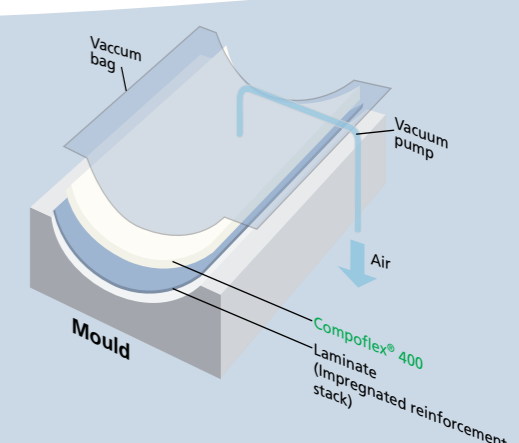

Vacuum bagging using Compoflex®

Compoflex® 400 properties		
Thickness at 2 kPa	mm	1.9
Resin Capacity	cm <sup>3</sup> /m <sup>2</sup>	1.135
Tear Strength (MD)	N	515
Tear Strength	N	310
Pore Size	µm	<10
Composition		100% Polypropylene
Process		Vacuum bagging

## The Compoflex® network

Through our distributors and technical consultants, Fibertex A/S is pleased to provide you with detailed information on where, how and why to use Compoflex®.

Fibertex A/S is certified according to EN ISO 9001 and ISO 14001 and Compoflex® is manufactured according to current European technical and environmental regulations.

The fabric is made from 100% polypropylene which only produces CO, CO<sub>2</sub> and water when incinerated at temperatures higher than 600°C.

For more information about the Compoflex® products please contact Fibertex, your local distributor or consult [www.compoflex.dk](http://www.compoflex.dk)